

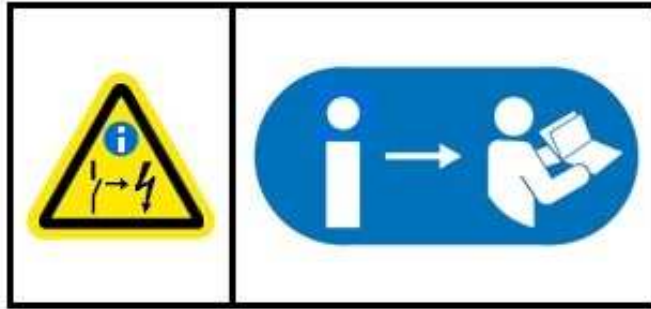



## **Electric switchboard AE-BU11MW**

### **Contents**

1. Technical Report ..... sheet TR 1-4
2. Electrical Diagram .... sheet 1-17



<b>DANGER</b>	
	<p><b>RISK OF ELECTRIC SHOCK!</b></p> <p>Certain machine electrical components <u>still remain</u> live when the main switch is turned to 'OFF' off.</p> <p>These are:</p> <ul style="list-style-type: none"> <li>• Incoming electrical supply terminal block components, up to the main switch</li> <li>• Heating function components</li> <li>• Externally supplied interface signals</li> </ul> <p>The corresponding circuits use orange-coloured wires. For detailed information refer to the electrical schematics.</p> <p>Before working on these components, you must make sure the associated voltage supplies are switched off (for example, lockout / tagout (LOTO) procedure of the corresponding supply by the customer.</p>

## SAFETY REGULATIONS



**During controller operation certain items are under dangerous voltage! Non-observance of safety instructions can result in death, serious injuries or material damage.**  
**Only specialist personnel may carry out transport, installation and commissioning work.**  
**The applicable valid standards as well as the national and / or company-specific accident prevention regulations are to be observed.**

The following safety instructions are to be observed:

The installation, commissioning, troubleshooting as well as repair of the controller may only be carried out by qualified personnel that is familiar with the corresponding operating instructions.

Device connection and installation has to follow all the valid standards, state and local regulations. Proper grounding and conductor dimensioning as well as proper short-circuit proofing have to be ensured. These measures serve to ensure the safety of the plant and of the operating personnel.

Before carrying out safety checks, maintenance work and repair measures ensure that all the power supplies are switched off, are secured against being switched on unintentionally and are marked correspondingly.

Only test devices that are in technically perfect condition and are suitable for the respective measurement may be used to carry out measurements!

The instructions specified in the respective operating instructions are to be followed strictly! It is mandatory that hazard, warning and safety instructions are followed!

All doors and covers are to be kept closed during the controller operation. If cooling devices are installed in the controller, ensure that these systems operate trouble-free. These include the regular cleaning of the filters, in as far as they exist.

## Technical Report

### Electric switchboard AE-BU11MW

#### 1. General

AE-BU11MW is an indoor, metal sheet cabinet designed for control and powering of the blower unit and complies with EN 60204-1 and EN 61439-1. The cabinet is totally enclosed and has following dimensions: 1400x600x400mm (HxWxL)

The switchboard consists of electric components, which ensure starting, running and safe operation of 11 kW / 380-415 V +/-10% 50/60 Hz blower package. The switchboard is secured against short circuit by main switch/circuit breaker – 3F1. Start and blower speed control is controlled by frequency converter (FC) -4G2. Its protection circuits protect the blower motor from over-current. Blower cabinet fan motors -3M4 and -3M6 are powered by 230 VAC, 50/60 Hz isolation transformer -3T5. Its primary winding is protected by circuit breaker -3Q3. Blower fan -3M4 is protected by circuit breaker -3Q5, switchboard fan –3M6 is protected by circuit breaker -3Q6 and started by auxiliary relay -6K1. Power supply -3U6 powers AECon controller -3A8 with 24 VDC. Its primary wiring is protected by circuit breaker -3Q4, control circuits are protected by circuit breaker -3Q7. AECon controller -3A8, EMERGENCY STOP button -5S7 and control handle of the main switch/circuit breaker are located on the switchboard door.

The electric switchboard shall be connected to the main power supply by WL01 cable in size 4x4mm<sup>2</sup>. The blower motor is connected by shielded cable WL02 YSLCY 4x6 mm<sup>2</sup>. Fan motor –3M4 is connected by WL03 YSLY-JZ 3x1 cable. Pressure sensor –5B1 is connected by WS02 PUR 4x0,34 cable. Remote control 0-10V should be connected WS04 LIYCY 2x0,5 cable. Air temperature sensor –5B3 is connected by WS05 SIHF 2x0,34 cable. Motor thermistor -5B5 is connected by WS06 YSLY-OZ 2x0,75 cable. Cables from and into the switchboard shall be installed from the bottom of the switchboard.

**ATTENTION! When working on the device, it is necessary to switch it off from the power supply by setting off the main circuit breaker. There is a voltage on input terminals even when the main switch is switched off.**

#### 2. Function description

After switching on the main switch/circuit breaker –3F1 of the control handle, blower is ready to start. Please see the Danfoss frequency converter manual (Annex to the Technical report) to set the drive parameters. Press push START [I] button on the control unit AECon –3A8. The machine will start. Please note, that the Auto and Remote switch is not operational when the machine is running.

It is possible to read current value of the blower charge/discharge pressure on the display AECon –3A8. Please check the AECon manual to read the process values and/or set the control unit parameters.

It is possible to control the blower by remote command through NO contact via terminal connectors –X5:3, -X5:6. The blower speed can be controlled by remote control 0-10V via terminal connectors -X5:21, -X5:22. The current condition of blower is reported via zero-potential contacts -X5:1, -X5:2 - connected (NO) ..... operation, –X5:7, -X5:8 connected (NC) ..... blower in Alarm.

Danfoss drive is monitoring the system pressure, temperature and motor current, as well as other measured values and will stop the machine operation when the error occurs. The errors and warnings are shown on the AECon display. It is possible to put blower into operation after the defect has been eliminated.

### 3. Basic technical parameters

Rated voltage .....	3L+PE AC 380-415V +/-10% 50/60Hz
Rated current .....	25A
FLA .....	21A
Short circuit resistance .....	25kA
El. protection .....	IP54, after opening the cover IP20
Protection from dangerous touch .....	automatic disconnection from the source
Switchboard dimensions .....	1400x600x400mm
Weight – switchboard + control panel .....	75kg
Design according to .....	EN 60204-1 and EN 61439-1
Drawing documentation .....	AR100112
Ambient temperature .....	0 to 45°C
Humidity range .....	50% at 40°C to 90% at 20°C
Altitude up to .....	1000m

### 4. Technical specification

Metal sheet cabinet Rittal AX1059.000, dimensions 800x600x400mm

Switchboard base with dimensions 600x600x400

Item	Marking	description, type, function, manufacturer	QTY, length (m)
1.	-3A8	AECon controller HMI, ARDAT Systems, language versions EN / DE	1 pc
2.	-3F1	Main switch/circuit breaker, MC125131, 25A, 440V, Schrack	1 pc
3.	-3Q3	Circuit breaker C2A, P1MB2PC02, protects transformer -3T5 from short circuit, Lovato	1 pc
4.	-3Q4	Circuit breaker C1A, P1MB2PC01, protects power supply -3U6 from short circuit, Lovato	1 pc
5.	-3Q5	Circuit breaker C2A, P1MB1PC02, blower fan protection -3M4 from short circuit, Lovato	1 pc
6.	-3Q6	Circuit breaker C2A, P1MB1PC02, switchboard fan protection -3M6, Lovato	1 pc
7.	-3Q7	Circuit breaker C2A, P1MB1PC02, protects control circuits 24VDC, Lovato	1 pc
8.	-3T5	Transformer, LP824040, 400VA, 400/230V, fan supply voltage, Schrack	1 pc
9.	-3U6	Power source, WDR-60-24, 60W, 180-550VAC/24VDC, control voltage, Mean Well	1 pc
10.	-3M6	Fan, SK3239.700, 14,7W, 0,1A, 230V, 50Hz, switchboard cooling, Rittal	1 pc
11.	-4G2	Frequency converter with control panel, FC280P11K, 11kW, 380-480V, Danfoss	1 pc

12. -5B1	Pressure sensor, HUBA 528, 7-33VDC, measurement of inlet air pressure, Huba, outside of switchboard	1 pc
13. -5B3	Temperature sensor, TSB 060, NC 140°C, measurement of outlet air temp, Sensit, outside of switchboard	1 pc
14. -5S7	Controller head MM263467, NC unit MM216378, EMERGENCY STOP, Schrack	1 pc
15. -6K1	Relay, RS500024, 24VDC, 6A + socket, auxiliary relay for control circuits, Schrack	1 pc
14. -6K2	Relay, RXT21LC4, 24VDC, 5A + socket, auxiliary relay for control circuits, Schrack	1 pc
15. -X1	Terminal box, 3x WT6 + 1x WT6 PE, switchboard power supply in, Wieland	1 pc
16. -X2	Terminal box, 1x WT2,5 + 1x WT2,5 N + 1x WT2,5 PE, output for blower fan supply, Wieland	1 pc
17. -X3	Terminal EMC, 1x SFZ + 2x LFZ, fixing the cable shield, Icotek	1 pc
18. -X4,-X5	Terminal box, WT 2,5 ... 4+10 pcs, external signals, Wieland	1 pc

### Cable leading

1. WL01	CYKY 4x6, supply mains of the blower	not included
2. WL02	YSLCY 4x4, current supply of mains engine -4M2, Tekaben	5 m
3. WL03	YSLY-JZ 3x1, current supply of fan engine -3M4, Tekaben	5 m
4. WS02	PUR 4x0,34, connection pressure sensor -5B1 witch frequency converter -4G2, IFM	5 m
5. WS04	LIYCY 2x0,5, remote control 0-10V	not included
6. WS05	SIHF 2x0,34, connection temperature sensor -5B3 witch freq. converter -4G2, Tekaben	5 m
7. WS06	YSLY-OZ 2x0,75, connection thermistor -5B5 with frequency converter -4G2, Tekaben	5 m
8. WS07	YSLY-OZ 2x1, external control Start / Stop	not included
9. WS08	YSLY-OZ 4x1, external signals connected	not included





Umgebungstemperatur / Ambient temperature / Température ambiante: 0 to 45°C  
 Feuchtebereich / Humidity range / Humidité relative: 50% at 40°C to 90% at 20°C  
 Höhe / Altitude / Altitude: up to 1500M

Customer power supply  
 3L+PE 380-415V +/-10% 50/60Hz  
 Compatible with networks TN, TT, IT\*

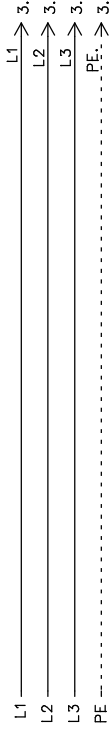

\*IT: The frequency inverter settings must be adjusted for the IT network.  
 Please, contact the manufacturer for more details.

Power	Busch Article N°	Frequency inverter typ	Control box size (mm)	FLA (A)	Protection with fuse	Wire gauge input min.	Control box N°	Main switch type
5,5 kW		134U2985-FC280P5K5	600x380x350		C20	2,5mm <sup>2</sup>	AE-BU5MW	MC120131 (20A)
7,5 kW		134U2986-FC280P7K5	600x380x350		C20	4mm <sup>2</sup>	AE-BU7MW	MC120131 (20A)
<b>11 kW</b>		<b>134U2987-FC280P11K</b>	<b>1400x600x400</b>	<b>21</b>	<b>C25</b>	<b>6 mm<sup>2</sup></b>	<b>AE-BU11MW</b>	<b>MC125131 (25A)</b>
15 kW		134U2988-FC280P15K	1400x600x400		C32	6mm <sup>2</sup>	AE-BU15MW	MC132131 (32A)
18,5 kW	2000095587	134U2989-FC280P18K	1400x600x400		C40	10mm <sup>2</sup>	AE-BU18MW	MC140131 (40A)
22 kW		134U2990-FC280P22K	1600x600x400		C50	10mm <sup>2</sup>	AE-BU22MW	MC150131 (50A)
30 kW		131F0433-FC302P22K	1600x600x400		C63	16mm <sup>2</sup>	AE-BU30FW	MC163131 (63A)
37 kW		131F0435-FC302P30K	1600x600x400		C80	25mm <sup>2</sup>	AE-BU37FW	MC180131 (80A)
45 kW		131F0436-FC302P37K	1800x800x400		C100	25mm <sup>2</sup>	AE-BU45FW	MC110131 (100A)
55 kW		131F0439-FC302P45K	1800x800x400		C125	35mm <sup>2</sup>	AE-BU55FW	MC112131 (125A)
75 kW		131F0440-FC302P55K	1800x800x400		C160	50mm <sup>2</sup>	AE-BU75FW	MC116131 (160A)
90 kW		131F0446-FC302P75K	1800x800x400		C200	70mm <sup>2</sup>	AE-BU90FW	MC220131 (200A)

DESIGNED BY:

ML

CHECKED:

DK

DATE OF CREATION:

9.10.2025

A 9.10.2025

B 9.10.2025 6K2 description, b/w ver.

C 9.10.2025 Wires color L1, L2, L1, L3,1

D 9.10.2025 Emergency stop button

INDEX DATE MODIFICATION

DES.

Schaltplan

Electrical schematics

Schéma électriques

DOCUMENT No:

AR100112

TYR Blower

Stromkreise des Kunden

Customer power supply

Circuits d'alimentation du client

SHEET

2

◀ 1

3 ▶

Software SEE V8RT

**BYUSCH**



3A8 HMI AFECON

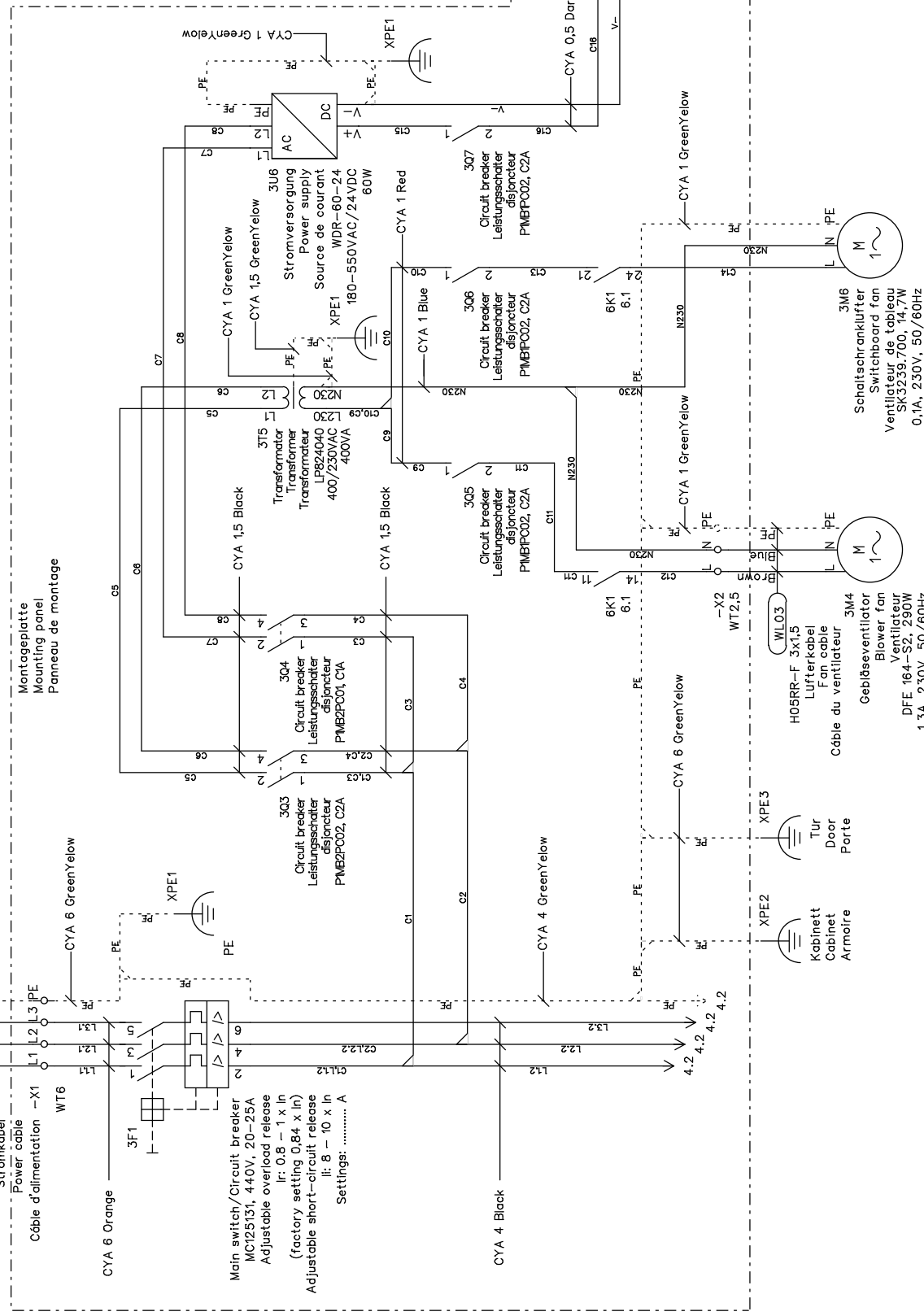

**TYR Blower**  
 Hauptstromkreise  
 Main circuits  
 Circuits principaux

Schaltplan  
 Electrical schematics  
 Schéma électriques  
**DOCUMENT No:**  
 AR100112

INDEX	DATE	MODIFICATION	DES.
A	9.10.2025	Initial version	ML
B	9.10.2025	6K2 description, b/w ver.	ML
C	9.10.2025	Wires color L.1, L.2.1, L.3.1	ML
D	9.10.2025	Emergency stop button	ML

**DESIGNED BY:**  
 ML  
**CHECKED:**  
 DK  
**DATE OF CREATION:**  
 9.10.2025



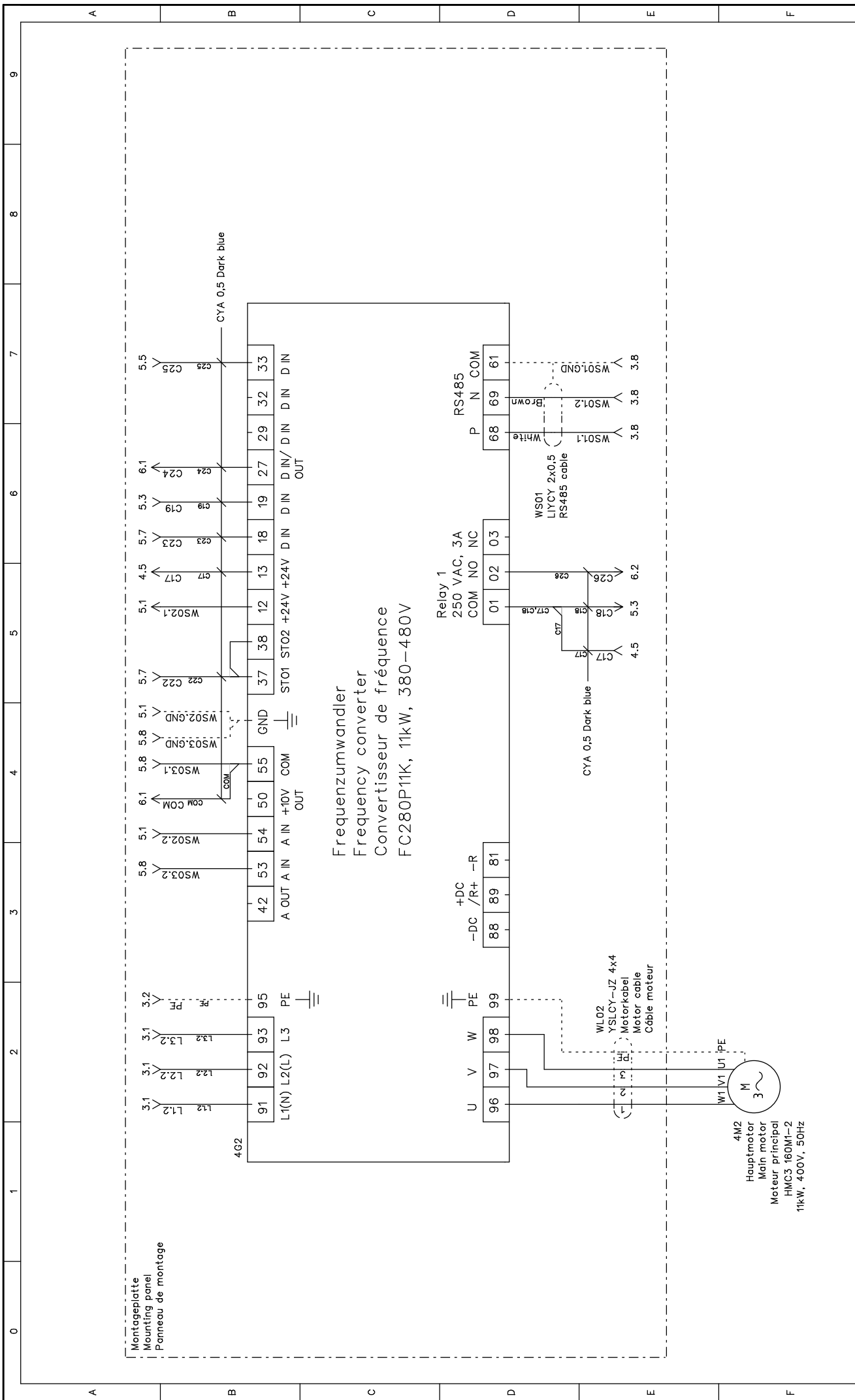

		DESIGNED BY:		9.10.2025	
		ML	ML	INDEX	DATE
CHECKED:		9.10.2025		MODIFICATION	
DK	9.10.2025	Emergency stop button		DES.	
Wires color L.1, L.2.1, L.3.1		Initial version		Schaltplan	
6K2 description, b/w ver.		6K2 description, b/w ver.		Electrical schematics	
9.10.2025		9.10.2025		Schéma électriques	
9.10.2025		9.10.2025		DOCUMENT No:	
9.10.2025		9.10.2025		AR100112	
TYR Blower		TYR Blower		SHEET	
Frequenzumwandler		Frequenzumwandler		4	
Frequency converter		Frequency converter		3	
Convertisseur de fréquence		Convertisseur de fréquence		5	
				Software SEE VBR1	

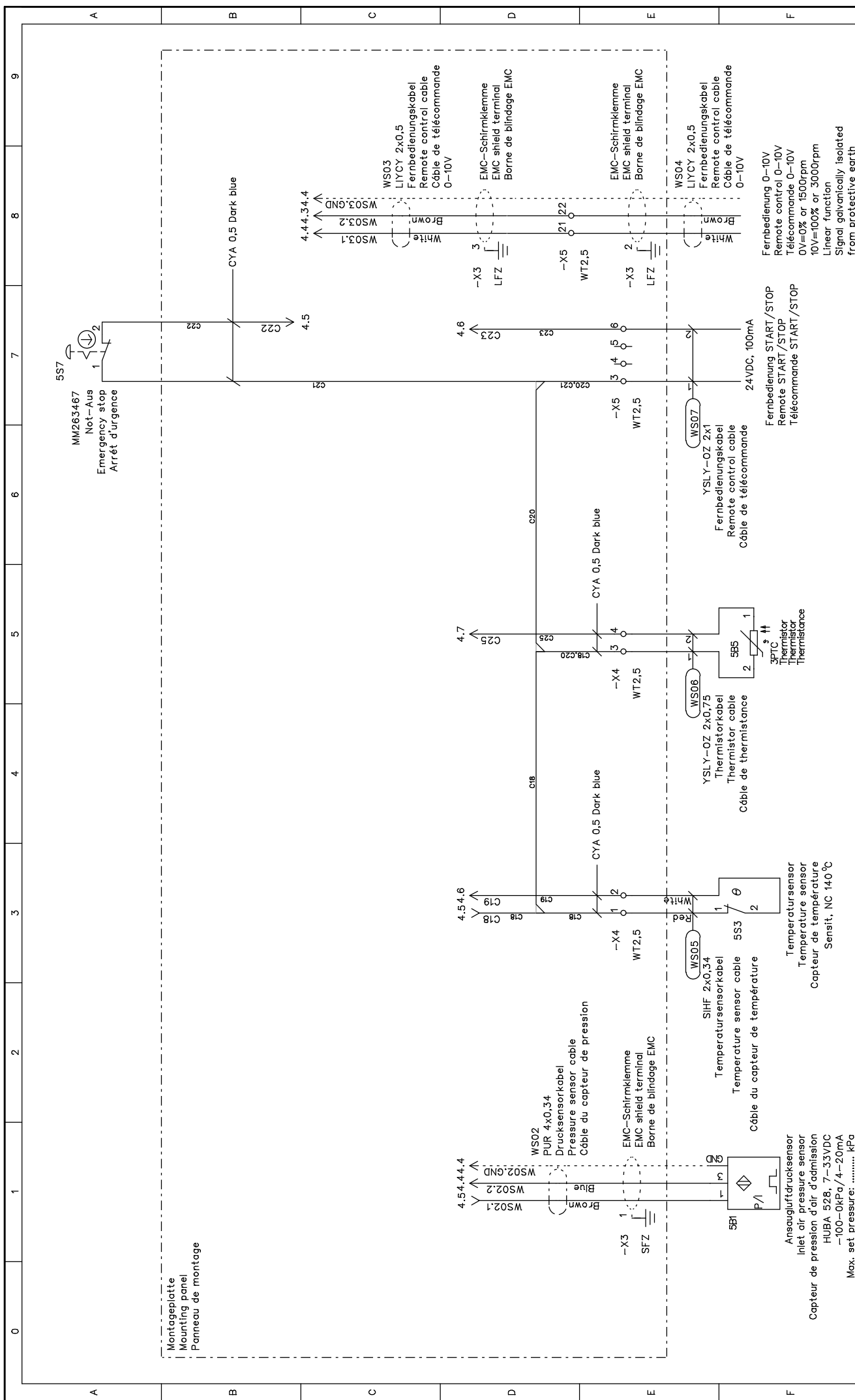

**DESIGNED BY:**  
ML

**CHECKED:**  
DK

**DATE OF CREATION:**  
9.10.2025

**INDEX**

A	9.10.2025	Initial version	ML
B	9.10.2025	6K2 description, b/w ver.	ML
C	9.10.2025	Wires color L.1, L.2.1, L.3.1	ML
D	9.10.2025	Emergency stop button	ML

**MODIFICATION**

**DES.**

**TYR Blower**

Analoge und digitale Eingänge  
Analog and digital inputs  
Entrées analogiques et numériques

Schaltplan  
Electrical schematics  
Schéma électriques

**DOCUMENT No:**  
AR100112

**SHEET**  
5

4 6

Software SEE V8RT

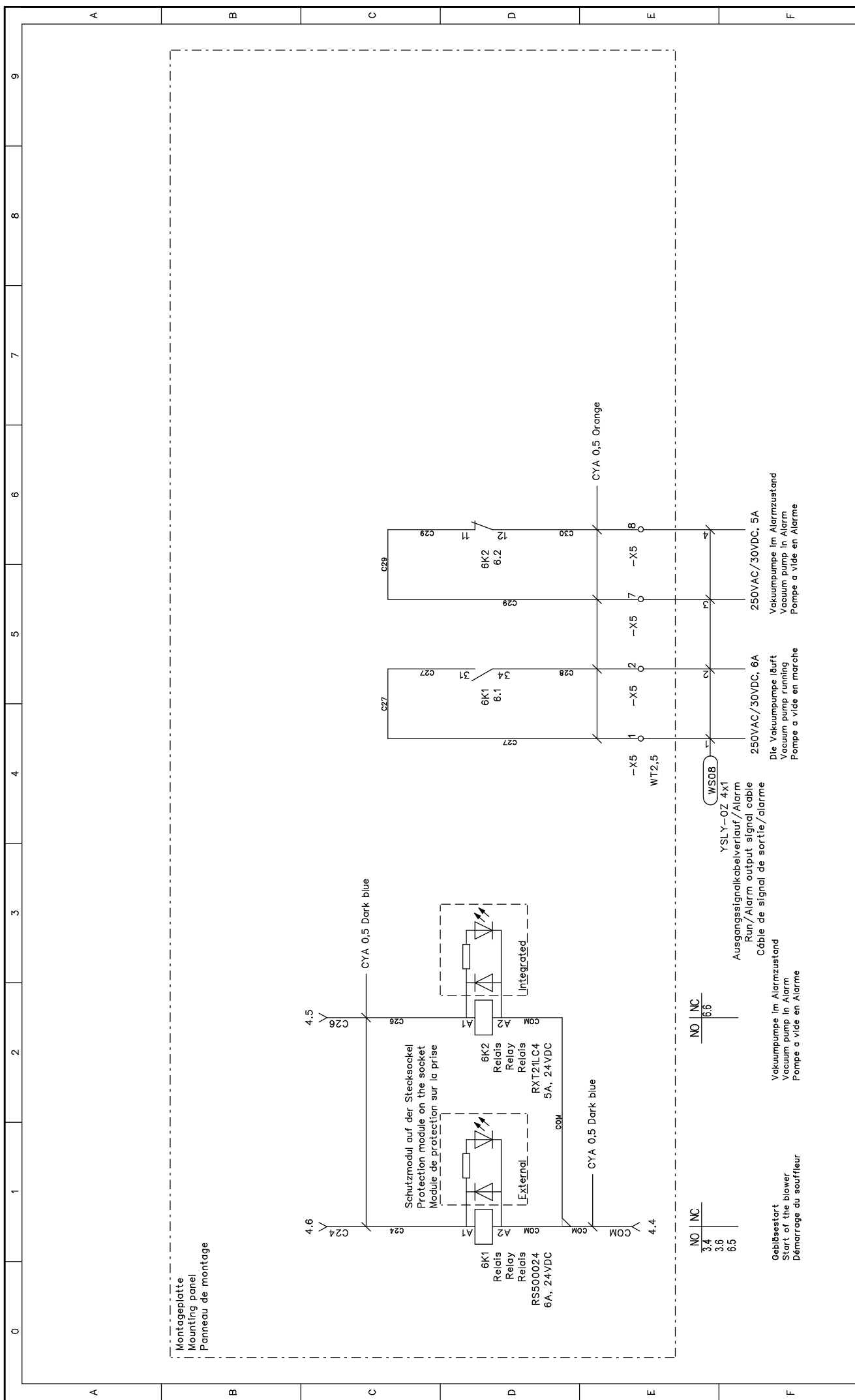

		DESIGNED BY:		A	9.10.2025	Initial version	ML	Schaltplan Electrical schematics Schéma électriques	TYR Blower Relais und digitale ausgänge Relay and digital outputs Sorties relais et numériques	SHEET 6
		CHECKED:		B	9.10.2025	6K2 description, b/w ver.	ML			
		DATE OF CREATION:		C	9.10.2025	Wires color L1.1, L2.1, L3.1	ML	DOCUMENT No: AR100112	Relais und digitale ausgänge Relay and digital outputs Sorties relais et numériques	6 5 7
		DATE		D	9.10.2025	Emergency stop button	ML			
		INDEX		DATE		MODIFICATION	DES.	Software SEE V8RT		

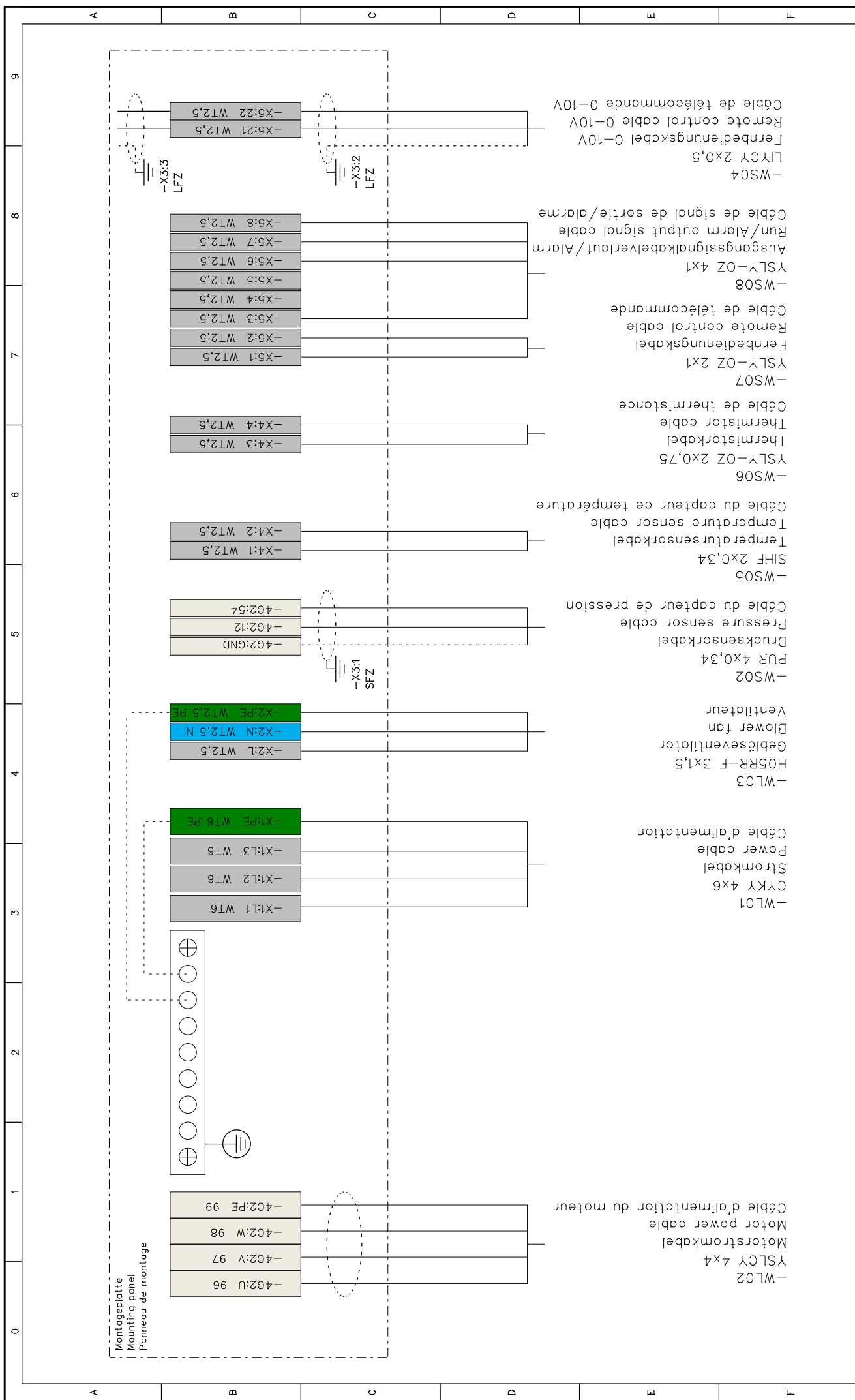



DESIGNED BY:  
ML

CHECKED:  
DK

DATE OF CREATION:  
9.10.2025

INDEX	DATE	MODIFICATION
A	9.10.2025	Initial version
B	9.10.2025	6K2 description, b/w ver.
C	9.10.2025	Wires color L1.1, L2.1, L3.1
D	9.10.2025	Emergency stop button

Schaltplan  
Electrical schematics  
Schéma électriques

**DOCUMENT No:**  
AR100112





**TYR Blower**  
Anschlussklemmen  
Connection terminals  
Bornes de connexion

SHEET  
7

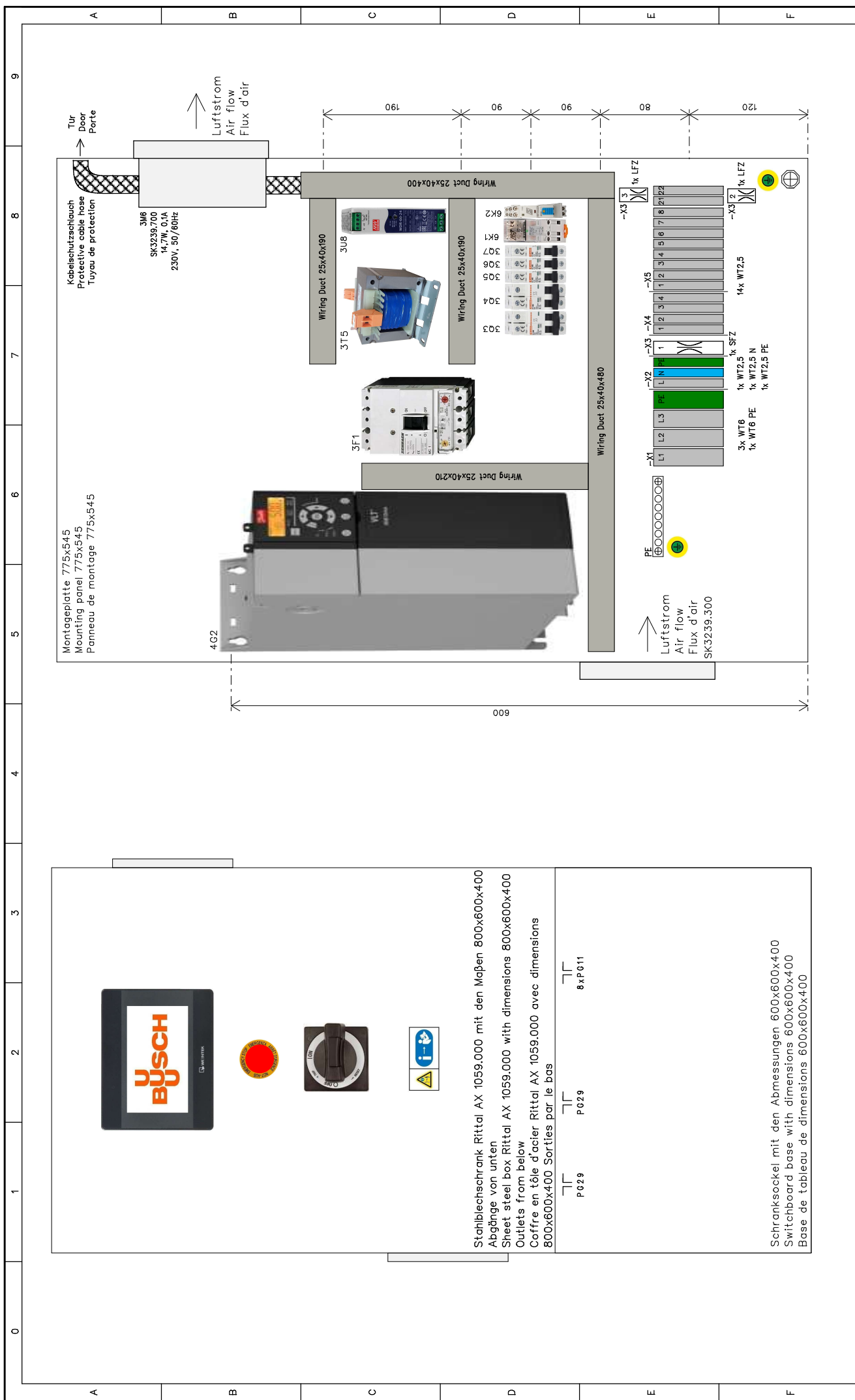
◀ 6 8 ▶

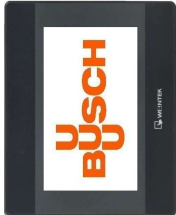
Software SEE V8RT



Stahlblechschrank Rittal AX 1059.000 mit den Maßen 800x600x400  
Abgänge von unten  
Sheet steel box Rittal AX 1059.000 with dimensions 800x600x400  
Outlets from below  
Coffre en tôle d'acier Rittal AX 1059.000 avec dimensions 800x600x400 Sorties par le bas

P029 P029 P029 8xP011

Schranksockel mit den Abmessungen 600x600x400  
Switchboard base with dimensions 600x600x400  
Base de tableau de dimensions 600x600x400

<b>BYUSCH</b>	<b>DESIGNED BY:</b>		A	9.10.2025	Initial version	ML
	<b>CHECKED:</b>		B	9.10.2025	6K2 description, b/w ver.	ML
	<b>DATE OF CREATION:</b>		C	9.10.2025	Wires color L1.1, L2.1, L3.1	ML
	9.10.2025		D	9.10.2025	Emergency stop button	ML
			<b>INDEX</b>	<b>DATE</b>	<b>MODIFICATION</b>	<b>DES.</b>
<h2 style="margin: 0;">TYR Blower</h2> <p style="margin: 0;">Dimensionale ansicht Dimensional view Vue dimensionnelle</p>						
<p style="margin: 0;">Schaltplan Electrical schematics Schéma électriques</p> <p style="margin: 0;"><b>DOCUMENT No:</b> AR100112</p>						
<p style="margin: 0;">Software SEE V8RT</p>						
<p style="margin: 0;">SHEET</p> <p style="font-size: 2em; margin: 0;">8</p> <p style="margin: 0;">◀ 7 9 ▶</p>						















# Drahtliste / Wire list / Liste des fils

No	From	To	Type	Colour	Squate
L1.1	-X1:L1	3F1:1	H07 V-K 1x4. Black	Orange	6
L2.1	-X1:L2	3F1:3	H07 V-K 1x4. Black	Orange	6
L3.1	-X1:L3	3F1:5	H07 V-K 1x4. Black	Orange	6
L1.2	3F1:2	4G2:91	H07 V-K 1x4. Black	Black	4
L2.2	3F1:4	4G2:92	H07 V-K 1x4. Black	Black	4
L3.2	3F1:6	4G2:93	H07 V-K 1x4. Black	Black	4
PE	-X1:PE	XPE1:PE	H07 V-K 1x4. Green yellow	Green yellow	4
PE	XPE1:PE	XPE2:PE	H07 V-K 1x6. Green yellow	Green yellow	6
PE	XPE2:PE	XPE3:PE	H07 V-K 1x6. Green yellow	Green yellow	6
PE	XPE1:PE	4G2:95	H07 V-K 1x4. Green yellow	Green yellow	4
PE	XPE1:PE	-X2:PE	H07 V-K 1x1. Green yellow	Green yellow	1
PE	-X2:PE	3M6:PE	H07 V-K 1x1. Green yellow	Green yellow	1
PE	XPE1:PE	3T5:PE	H07 V-K 1x1. Green yellow	Green yellow	1,5
PE	3T5:PE	3T5:N230	H07 V-K 1x1. Green yellow	Green yellow	1
PE	XPE1:PE	3U6:PE	H07 V-K 1x1,5. Green yellow	Green yellow	1
PE	3U6:PE	3U6:V-	H07 V-K 1x1,5. Green yellow	Green yellow	1
PE	XPE1:PE	3A8:PE	H07 V-K 1x1. Green yellow	Green yellow	1
N230	3T5:N230	-X2:N	H07 V-K 1x1. Blue	Blue	1
N230	3T5:N230	3M6:N	H07 V-K 1x1. Blue	Blue	1
V-	3U6:V-	3A8:N	H07 V-K 1x0,5. Dark blue	Dark blue	0,5
C1	3F1:2	3Q3:1	H07 V-K 1x1,5. Black	Black	1,5
C2	3F1:4	3Q3:3	H07 V-K 1x1,5. Black	Black	1,5
C3	3Q3:1	3Q4:1	H07 V-K 1x1,5. Black	Black	1,5
C4	3Q3:3	3Q4:3	H07 V-K 1x1,5. Black	Black	1,5
C5	3Q3:2	3T5:L1	H07 V-K 1x1,5. Black	Black	1,5
C6	3Q3:4	3T5:L2	H07 V-K 1x1,5. Black	Black	1,5
C7	3Q4:2	3U6:L1	H07 V-K 1x1,5. Black	Black	1,5
C8	3Q4:4	3U6:L2	H07 V-K 1x1,5. Black	Black	1,5
C9	3T5:L	3Q5:1	H07 V-K 1x1. Red	Red	1

	DESIGNED BY:	Schaltplan		<b>TYR Blower</b> Drahtliste Wire list Liste des fils	SHEET <b>16</b> ◀15 17▶
	ML	Initial version	Electrical schematics		
	CHECKED:	B/w ver.	Schéma électriques		
	DK	Wires color L1.1, L2.1, L3.1			
DATE OF CREATION:		Emergency stop button	<b>DOCUMENT No:</b>		
9.10.2025		INDEX	DATE	AR100112	
		MODIFICATION	DES.		

